

Installation Instructions

Modern gutter systems

Deepflow, No46 Ogee, Boxer, Box Eaves

ALIGATOR[®]



Applicable to

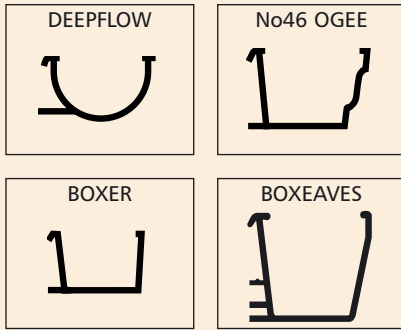

General Guidance

Preparation. Fascia boards should be in good condition, level and in linear alignment (straight). If required, packing shim plates should be fixed behind gutter brackets to achieve good alignment. The fascia should be capable of supporting the gutter when full of water, ice or snow. Where gutter is fixed to PVC-ue cellular fascia board, it is recommended that a timber support framework is installed behind the fascia to provide a straight and secure fixing surface.

Use standard metal work tools to cut or drill aluminium gutters. Angle grinders are not recommended. Where gutter or fittings are polyester powder coated, cut edges should be deburred and repainted with touch up paint, SC880.

Gutter position. Gutters must be installed level or to a fall of 1:600. The gutter should not be positioned at a level which causes rainfall to overshoot the gutter, i.e. too low, or where it is damaged by the high velocity impact of sliding snow, i.e. too high.

Jointing. Joint sealing must not be carried out in wet weather or in temperatures below 5°C or above 40°C. Joint surfaces must be perfectly clean and dry. Use a clean cloth and solvent cleaner SC108 to remove all traces of dirt or grease, which may not be visible.

Ensure that the gutter ends align with each other to ensure a stress free joint, allowing for thermal movement within the gutter joint.

Only Alutec high performance low modulus sealant SC101 must be used. Use of other sealants may result in early joint failure. Sealant over nine months old must not be used.

Fixing. To ensure the long term durability of aluminium gutter systems, it is vitally important to ensure that the fixing components are equally durable and capable of providing the necessary support. They must therefore be non corrosive, of a compatible material to ensure no electrolytic corrosion occurs and of the appropriate size. Only the recommended austenitic stainless steel screws must be used to fix gutters, whether direct, fascia or rafter bracket fixed.

If fixing to fascia boards made of materials other than wood, please contact the Alutec technical hotline for advice: 01234 344108.

Testing. On completion of an installation, blank off all gutter outlets. Fill gutter to overflow level and leave for 5 minutes, then check for leakage. Discharging the flood test water into rainwater pipes will identify any leaks in rainwater pipe joints. Any joints that fail should be taken apart, all sealant cleaned off, then re-sealed and re-tested.

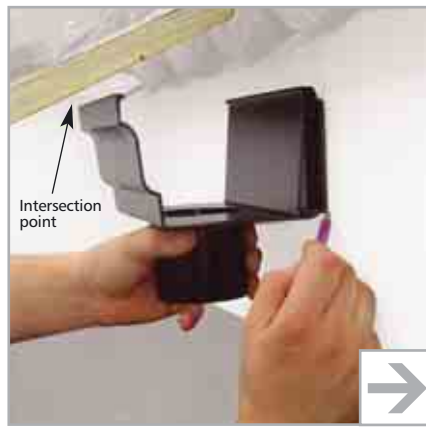

1. To set recommended gutter height, fix a straight batten on the lowest profile of the roof covering. The gutter can then be offered up to the intersection point (10mm below the pitch of roof, as shown).

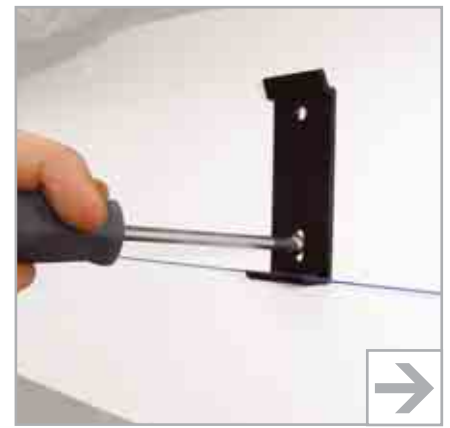

2. Fix fascia brackets using 32mm x No10 roundhead screw, SC201. Drilling pilot holes first is recommended. Insert a screw into the lower slot, adjust to the string line then secure by inserting and tightening the top screw.



6. Once fascia brackets are fixed, check the fascia board alignment and if required shim out brackets, using appropriate shim plates; Deepflow – SC380; Ogee No 46 – SC381; Boxer 160x100mm & 135x100mm – SC381; Boxer 120x80mm – SC382



7. To achieve a neat cut through the gutter, place a joint union into the gutter and use as a cut guide.



11. Check that factory fitted rubber compression spacers are fitted to the underside of the joint unions. Insert joint union, taking care not to remove sealant from the vertical faces.



12. Secure joint union into gutter by firstly engaging the rear upstand, then the front, by compressing downwards with the aid of the compression device, SC104.



3. Fix fascia brackets at 750mm centres, nominally level (600mm centres for Box Eaves gutter). A fall of 1:600 may be introduced but the aesthetic appearance of the gutter may be impaired.



4. Fix an additional fascia bracket centrally to one side only of each angle.



5. Fix an additional fascia bracket centrally to each outlet.



8. Hook the top rear edge of the gutter over the brackets. Then swing down to secure into the base of the brackets. Check that all brackets are fully engaged at the base.



9. Clean both gutter & union joint surfaces using a clean cloth and solvent cleaner, SC108. Ensure all surfaces are dry and dust free.



10. Apply two 8mm thick parallel beads of sealant, SC101 to each gutter end. Do not carry out jointing in wet conditions or temperatures below 5°C or above 40°C.



13. Point excess sealant well into the joint edges adding additional sealant if required.



14. Clean off any excess sealant to visible surfaces using solvent cleaner, SC108 and ensure that all joints have a 3 – 4mm expansion gap.

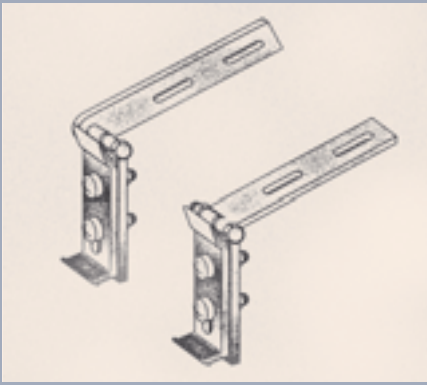

Fixing gutter to rafters

For top or side rafter fixing, use the universal adjustable rafter brackets; side (AC78) or (AC77) top. Remove and discard the fitted sliding cross plate and replace with standard snap fit fascia gutter brackets with the bolts provided, as illustrated.

Bracket centres will be dictated by the rafter which should not exceed 750mm. Internal/ external gutter corner angles and outlets should be independently supported. It is recommended that a timber bridge between adjacent rafters should be provided to which a rafter bracket can be fixed to fully support the outlet or angle.

Lightning links

Lightning Conductor Links (SC401) should be fitted where gutters are bonded to the lightning protection system. This is to provide electrical continuity across the gutter joints that are effectively insulated from one another by the gutter joint sealant.

1. Prior to installing the gutter, pre-drill 7mm holes through the rear of the gutter, 20mm from the top and 65mm from the end of the gutter.
2. Scrape off the paint to expose bare metal around the hole to both faces. This area should be equal to the diameter of the washer supplied.
3. Oxide inhibitor, SC402 must be applied to all contact faces.
4. Insert the bolt from the back of the gutter, apply a nut and washer from the inside and tighten.

5. Once the gutter is installed and the joints sealed, fit link strap to projecting threaded bolts, bending link strap as required to bridge over joint union.

6. Fit the nuts and washers and securely tighten.

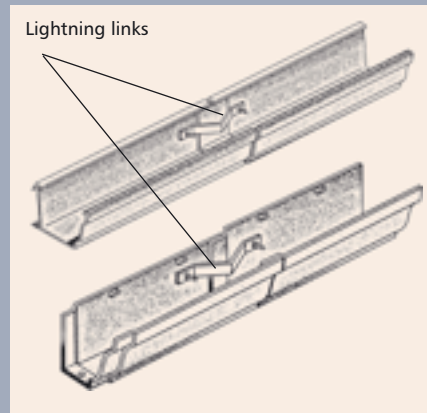

Site painting

Do not paint mill finish gutters after installation as paint will not bond to surfaces contaminated with silicone sealant. It is recommended that all components are individually painted prior to installation to ensure all surfaces are painted. Prior to application of paint, it is vitally important to ensure all surfaces are degreased with solvent cleaner, SC108, using a clean cloth which itself should be regularly replaced to prevent the spread of diluted grease. Prime surfaces with an "aluminium etch primer" or zinc phosphate, followed by two coats of good quality metal gloss paint. Two part synthetic or polyetherathene paints are recommended for durability. Ensure the paint is fully dry prior to contact with joint sealant. Partially dry paint may react with sealant, affecting reliability of gutter joint. If over painting new or aged polyester powder coated surfaces, rub down surfaces with a light abrasive scotch wool (not steel wool) to achieve a good key. Clean surfaces using a clean cloth and solvent cleaner, SC108 and apply top coat directly onto the prepared surface. No undercoats or primers are required.

Handling & storage

Gutters and pipes, particularly with polyester powder coated finishes, should be handled with care and should preferably be stored under cover on racks to prevent scratching or denting. All gutter and pipe lengths are supplied in protective polythene sleeving and components packed in cardboard boxes. If polyester powder coated products are stored outside, cover with a tarpaulin to guard against water ingress into the protective polythene tubing. If water becomes trapped within the polythene wrapping and left exposed to warm sunlight, it may leave permanent water stains on the paint finish. Mill finish goods to be installed in their natural state should also be stored undercover, to prevent uneven oxidization to visible surfaces. Once installed the surfaces will mature uniformly. Sealants should not be stored in temperatures below 0°C and kept away from any direct heat source. Solvent cleaners must be stored away from any direct heat or combustible source, preferably in an appropriate fire resistant storage cabinet.

Environmental

Ensure all packaging is disposed of responsibly in accordance with current waste disposal regulations. Aluminium is an infinitely recyclable material and therefore all off cuts should be disposed of at metal recycling depots.

Safety

The relevant safety regulations are outlined in the Health and Safety at Work Act 1974 and should be followed.

Refer to CDM regulations (Code of Practice and Designing for Health and Safety in Construction 1995).

Handling mill finished or polyester powder coated aluminium products does not pose any known health hazard, however it is recommended to wear protective gloves when handling mill finish aluminium.

Hazard instructions relating to sealant, solvent cleaner and touch up paint are printed on their respective containers and COSHH sheets are supplied with each consignment of goods and are available on request.

Further information

For Technical advice please call **01234 344108**
For general enquiries please call **01234 359438**
email: **enquiries@marleyalutec.co.uk**

marleyalutec.co.uk

Head Office

Lenham, Maidstone, Kent ME17 2DE

Technical services

Unit 1 (G-H), Viking Industrial Park, Hudson Road,
Elms Farm Industrial Estate, Bedford MK41 0LZ
Telephone: **+44 (0)1234 359438**
Fax: **+44 (0)1234 357199**

E&OE