

Installation Instructions

Downpipe systems



Downpipe systems

Eared downpipes. Fix via the ears (lugs) at each socket, using recommended dome head pipe screws, SC603 or SC221. See fig 1. Pipe clips should be fitted adjacent to branch and bend fittings using the same screws. See Fig 2.

Uneared downpipes. Pipe clips should be fitted directly under each pipe socket and additional clips at maximum 1.5m centres, using recommended dome head pipe screws, SC603 or SC221. Additional pipe clips must also be fixed adjacent to all bends and branches. See Fig 2.

Loose pipe sockets can be fitted to utilise pipe off cuts. Clean the inside of the socket with solvent cleaner SC108, then apply a 6mm diameter bead of sealant SC101 to the internal locating groove. Drive the socket onto the pipe with a mallet or block of wood.

Additional pipe spacing. Use 30mm Cast Bobbins Mill SC701 or SC711 PPC'd together with No16 x 75mm hexagonal screws, SC244 Mill or SC604 PPC'd. See Fig 3.

Thermal expansion gap. 4-5mm should be left within all socket joints to allow for free thermal movement. See Fig 4.

Cast pipe socket joints. Seal with a bead of sealant SC101. Circular pipe sockets only will require pipe filler foam SC911 caulked into the pipe socket prior to applying the sealant bead. See fig 4. This eliminates the risk of over spilling during heavy rain fall.

Hoppers. Fix using dome headed pipe screws, SC603 Mill or SC221 PPC'd.

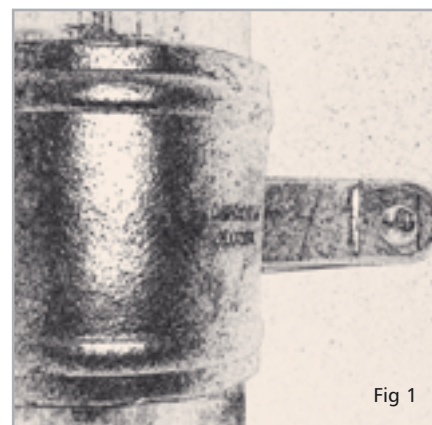

Fig 1

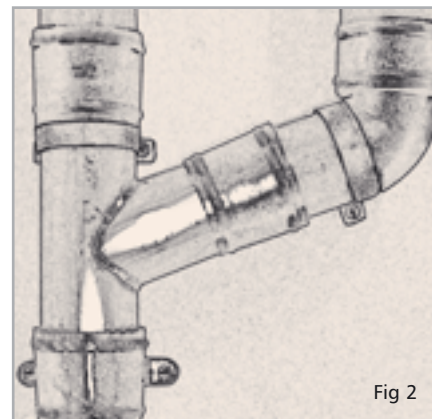

Fig 2

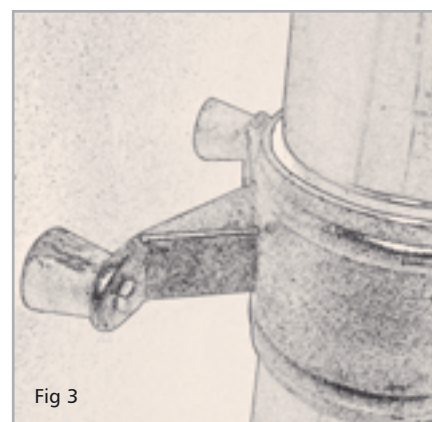

Fig 3

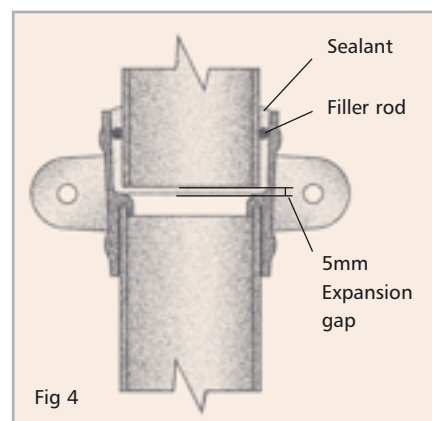

Fig 4

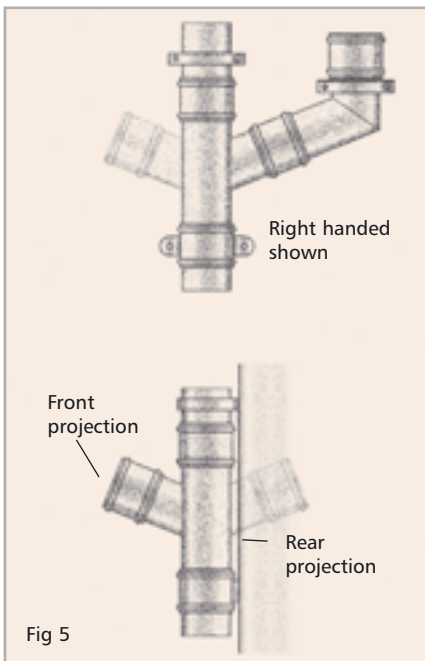

Fig 5

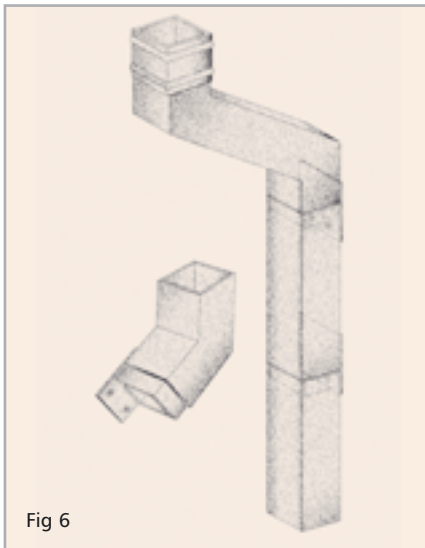

Fig 6

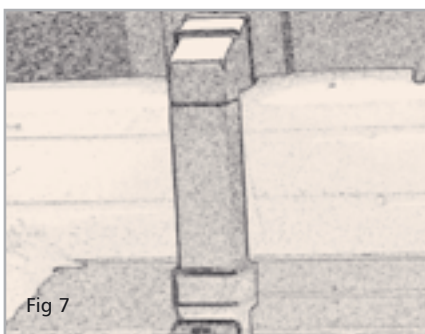

Fig 7

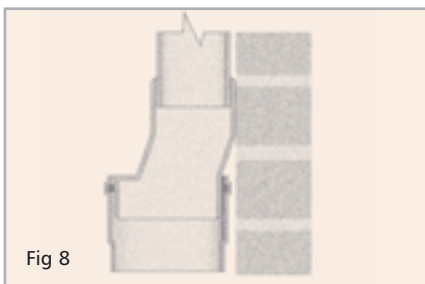

Fig 8

102 x 76mm downpipe. Fit with the 102mm face fixed back against the wall. Branches and bends connected to a down pipe must, therefore be of the correct orientation e.g. either left / right handed or front / back. As bends and branches do not have eared sockets they can be reversed. See Fig 5

Vandal resistant downpipes. Install from the top downwards, each fixing plate being concealed by the pipe below. Compatible counter sunk screws SC241 and appropriate wall plugs must be used. Vertical and sloping pipe joints do not require sealing, but the cast socket joint to the gutter outlet should always be sealed with sealant SC101.

- Bends and branches are supplied with loose fixing plates to be site fitted depending on handing of fitting. See Fig 6.
- Pipe offcuts can be used by fitting an internal joint spigot and sealing with sealant SC101, then fitting the fixing plate, making up a short pipe length.
- Connections to gutter outlets or hoppers can only be made via an uneared square / rectangular cast pipe socket, which should be fitted and sealed to the end of the connecting pipe.

Vortex® Downpipes. Installed with a pipe clip under each pipe socket and then at 1.5m centres with additional clips to support branches and bends. Use dome headed pipe screws SC603 or SC221. Vertical and sloping pipe sockets do not need sealing, but the joint to the gutter outlet should always be sealed with sealant SC101.

Classic 62 x 62mm downpipes. Designed for use with the Classic gutter system and hoppers only. Pipes are supplied plain ended allowing either eared, uneared pipe sockets or spigot bends to be inserted. Fix via eared sockets / pipe clips at 1.5m centres with additional clips at bends or branches. Use pipe screws SC231. Offset bends are made up on site of 2 bends RK332 with an appropriate cut length of pipe between them to achieve the required projection. All Classic pipe joints should be sealed with SC101 sealant. See Fig 7.

Square / Rectangular Pipe Drain Connections should be made using drain adaptors RSR370, RSR170 or RSR470 which incorporate a slip socket, allowing a joint to a fixed drain connection see Fig 8.

Lightning conductors

It is not recommended that downpipes be utilised as lightning conductors. A specialist engineer should be consulted.

Site painting

Do not paint mill finish gutters after installation as paint will not bond to surfaces contaminated with silicone sealant. It is recommended that all components are individually painted prior to installation to ensure all surfaces are painted. Prior to application of paint, it is vitally important to ensure all surfaces are degreased with solvent cleaner, SC108, using a clean cloth which itself should be regularly replaced to prevent the spread of diluted grease. Prime surfaces with an "aluminium etch primer" or zinc phosphate, followed by two coats of good quality metal gloss paint. Two part synthetic or polyurethane paints are recommended for durability. Ensure the paint is fully dry prior to contact with joint sealant. Partially dry paint may react with sealant, affecting reliability of gutter joint.

If over painting new or aged polyester powder coated surfaces, rub down surfaces with a light abrasive scotch wool (not steel wool) to achieve a good key. Clean surfaces using a clean cloth and solvent cleaner, SC108 and apply top coat directly onto the prepared surface. No undercoats or primers are required.

Handling & Storage

Gutters and pipes, particularly with polyester powder coated finishes, should be handled with care and should preferably be stored under cover on racks to prevent scratching or denting. All gutter and pipe lengths are supplied in protective polythene sleeving and components packed in cardboard boxes.

If polyester powder coated products are stored outside, cover with a tarpaulin to guard against water ingress into the protective polythene tubing. If water becomes trapped within the polythene wrapping and left exposed to warm sunlight, it may leave permanent water stains on the paint finish.

Mill finish goods to be installed in their natural state should also be stored undercover, to prevent uneven oxidization to visible surfaces. Once installed the surfaces will mature uniformly.

Sealants should not be stored in temperatures below 0°C and kept away from any direct heat source. Solvent cleaners must be stored away from any direct heat or combustible source, preferably in an appropriate fire resistant storage cabinet.

Environmental

Ensure all packaging is disposed of responsibly in accordance with current waste disposal regulations. Aluminium is an infinitely recyclable material and therefore all off cuts should be disposed of at metal recycling depots.

Safety

The relevant safety regulations are outlined in the Health and Safety at Work Act 1974 and should be followed.

Refer to CDM regulations (Code of Practice and Designing for Health and Safety in Construction 1995).

Handling mill finished or polyester powder coated aluminium products does not pose any known health hazard, however it is recommended to wear protective gloves when handling mill finish aluminium.

Hazard instructions relating to sealant, solvent cleaner and touch up paint are printed on their respective containers and COSHH sheets are supplied with each consignment of goods and are available on request.

Further information

For Technical advice please call **01234 344108**
For general enquiries please call **01234 359438**
email: enquiries@marleyalutec.co.uk

marleyalutec.co.uk

Head Office

Lenham, Maidstone, Kent ME17 2DE

Technical services

Unit 1 (G-H), Viking Industrial Park, Hudson Road,
Elms Farm Industrial Estate, Bedford MK41 0LZ
Telephone: **+44 (0)1234 359438**
Fax: **+44 (0)1234 357199**

E&OE