

INSTALLATION INSTRUCTIONS

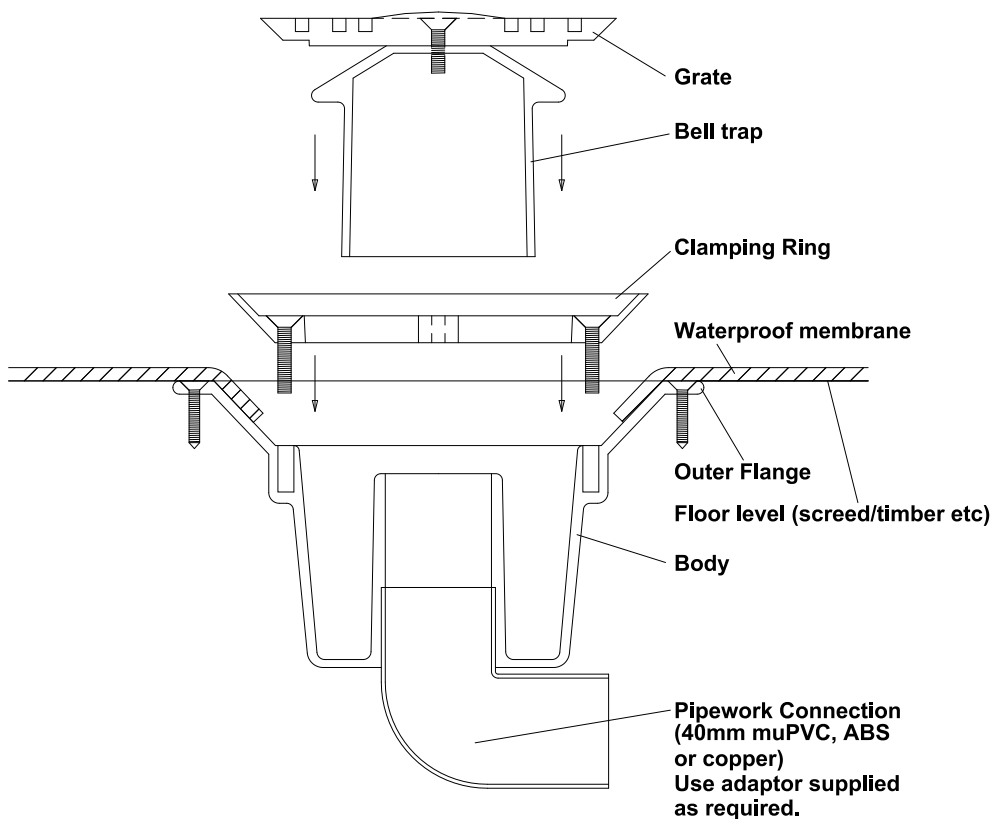

1. Recess "outer flange" into floor surface so that top of flange is level with the floor.

2. Connect waste pipe to outlet using adaptor supplied as required.

3. Screw down "outer flange" to the structural floor with countersunk screw via 4 holes provided.

4. Dress the waterproofing membrane into the dish of the outlet body. For sheet membranes use a silicone sealant to form a watertight seal between the outlet body and sheet material.

5. Secure the "clamping ring" over the waterproofing membrane with screws provided, ensuring the membrane is fully clamped into position.

6. Fit grate with attached "bell trap" to clamping ring with screws provided.

Part code: DF215



MARLEY ALUTEC LTD

Unit 1 (G-H) Viking industrial Park,
Hudson Road, Elms Farm Industrial Estate,
Bedford MK41 0LZ

Tel: 01234 359438 Fax: 01234 357199

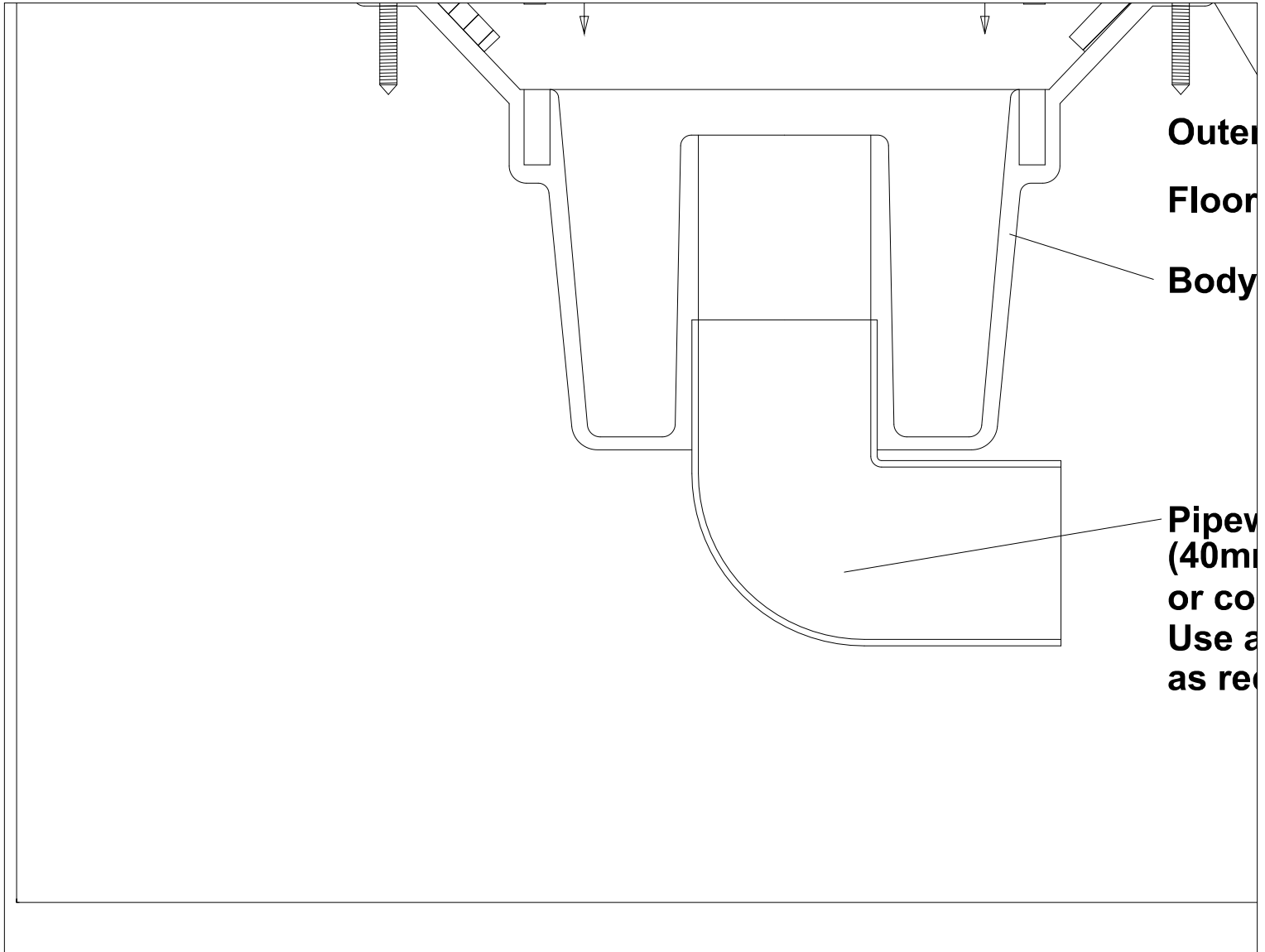

Outer

Floor

Body

Pipe

(40mm

or co

Use a

as rec